

## Double Action Floor Spring Door Closer - CE Marked To BS EN 1154 - Certifire Approved - Adjustable Power Size 1-4 - Supplied With Cover Plate & Double Action Accessories

### Product Images

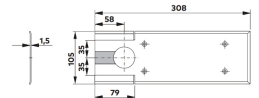
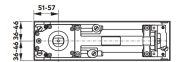
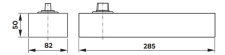
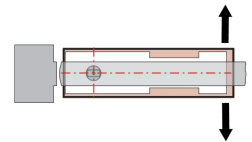

### Short Description

- Double action floor spring door closer.
- Floor mounted closer designed for doors that need to swing in two directions.
- Features individual controls for door speed, latching action and backcheck.
- Can be adjusted to suit door widths up to 1100mm wide.
- Max Door Width / Weight - 1100mm / 120Kg.
- Power adjustable by valve.
- CE marked to EN1154 - power size 1-4.

- Included in successful fire test to EN1634.
- Certifire approved.
- Declaration of performance (DoP) available.
- Satin stainless steel & satin brass cover plate options.
- **Complete kit includes; body, double action accessories and cover plate.**

## Description

---

## Floor Plate Finish Options:

- Satin stainless steel.
- Satin brass.

## Double Action:

- Allows the door to swing through 175 degrees (allows the door to swing in both directions).

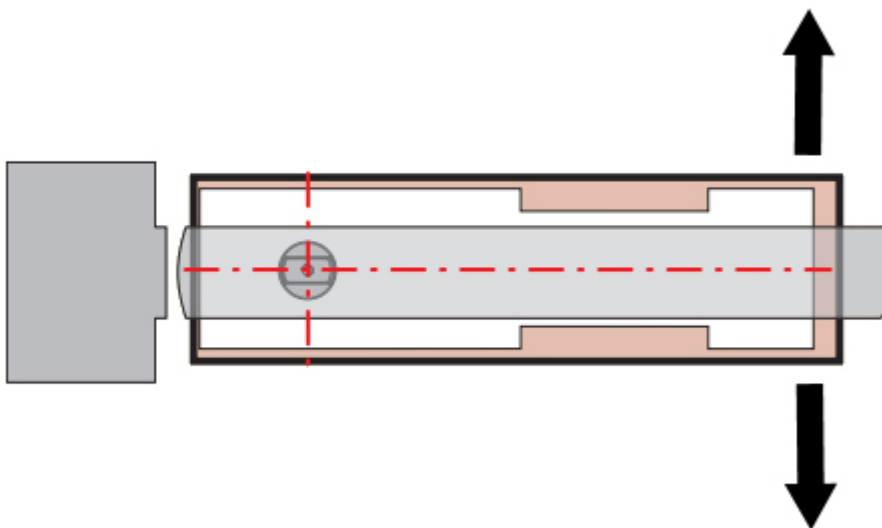

## Power Adjustment Via Spring:

- Separate power adjustment, by means of an allen key at the end of the closer body, this closer can be adjusted to suit door widths up to 110mm wide and up to 120kg in weight (EN power size 1-4)

## Functions:

1. Adjustable closing speed in the range 175° – 15°.
2. Adjustable closing speed in the range 15° – 0°.
3. Mechanical backcheck (from approx. 70°).
4. **Hold open function (NOT AVAILABLE WITH THIS FLOOR SPRING) - for hold open option see product 43536.**
- 5 Adjustable spring strength (EN 1-4).

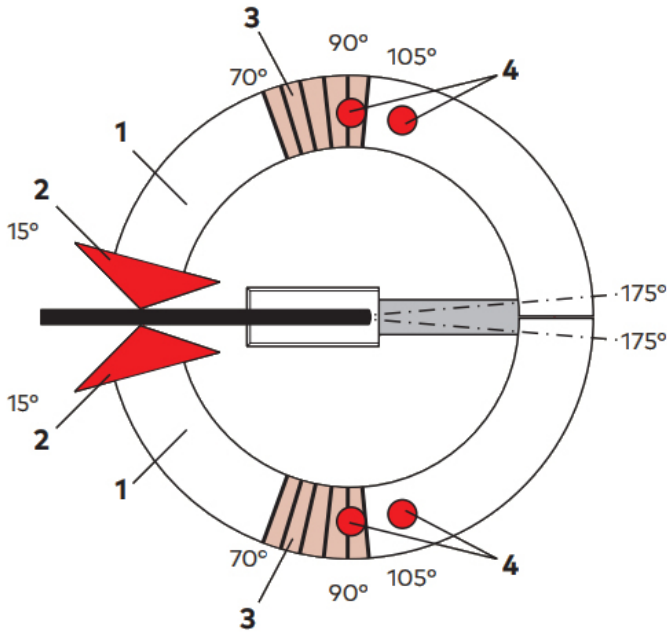
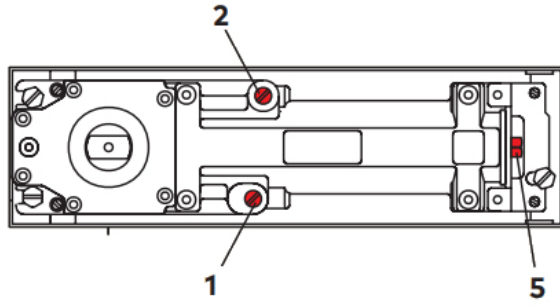

## Floor Spring Dimensions:

- Body Length - 285mm
- Body Height - 50mm
- Body Width - 82mm
- Cover Length - 308mm
- Cover Width - 105mm
- Cover Thickness - 1.5mm

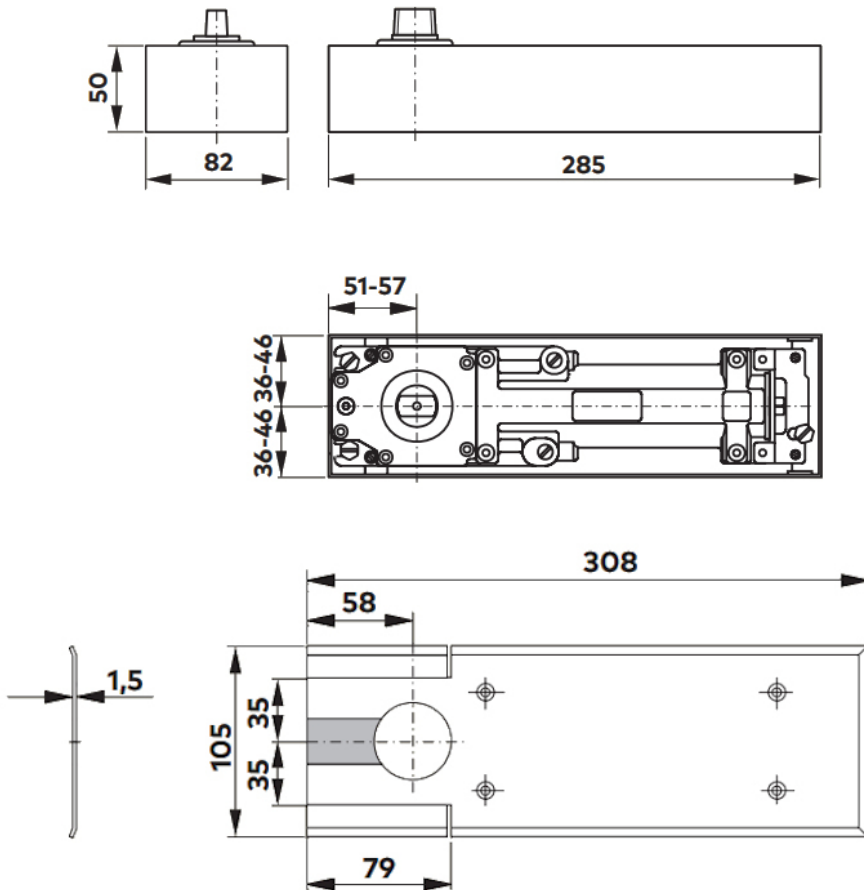

## Opening Forces - BS 8300:

The opening force (0-30 degrees) is less than 30N.

The opening force (30-60 degrees) is less than 22.5N

## Standards This Product Meets:

- CE Marked / UKCA Marked to EN1154 - power size 2-4.
- Included in successful fire test to EN1634.
- Certifire approved.
- Declaration of performance (DoP) available.

## Products in this set

---



**43534.1 - Double Action Floor Spring Door Closer - CE / UKCA Marked To BS EN 1154 - Certifire Approved - Adjustable Power Size 1-4 - Supplied With Cover Plate & Accessories - Satin Stainless Steel**



**43534.2 - Double Action Floor Spring Door Closer - CE / UKCA Marked To BS EN 1154 - Certifire Approved - Adjustable Power Size 1-4 - Supplied With Cover Plate & Accessories - Satin Brass Unlacquered**