**High Quality - Spoon End Design - Reversible Casement Window Fastener - Polished Brass
(Lacquered)**

Product Images



Description

- Heavy architectural quality range
- Spoon end design handle
- Traditional pattern casement window fastener
- A casement fastener is fixed on the side of the window and is the handle used to keep the window closed
- This fastener is reversible so can be used on windows hung on the left or right

Finish

- Polished brass - (shiny finish)

Dimensions

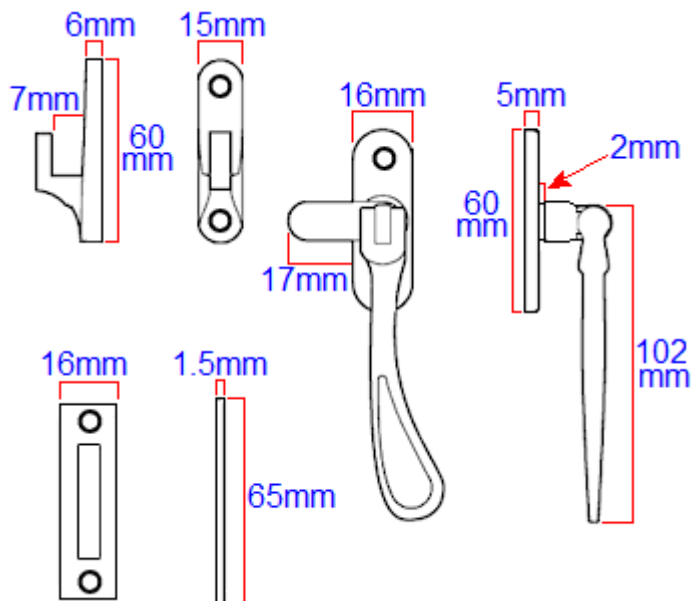

- Back Plate - Height - 60mm x Width - 16mm
- Handle Length - 102mm
- Tag Length - 17mm
- Step Distance - 2mm
- Mortice Plate - Height - 65mm x Width - 16mm
- Hook Plate - Height - 60mm x Width - 15mm

Important Info Before You Buy

- Suitable for wooden windows
- Comes supplied with mortice plate and hook plate
- For standard outward opening windows the mortice plate is used
- For double windows or where the window sits flush with the frame the hook plate is used
- This fastener is not suitable for use on weather stripped windows
- Matching window stay to open and close the window also available

Products in this set



15334.1 - Architectural Quality - Reversible Window Fastener - Polished Brass (Lacquered) - Each