

---

## Auto Locking Multipoint BlueMatic Motor Unit And Wires

### Product Images

---

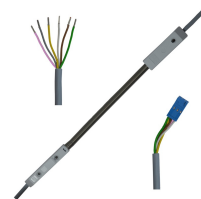

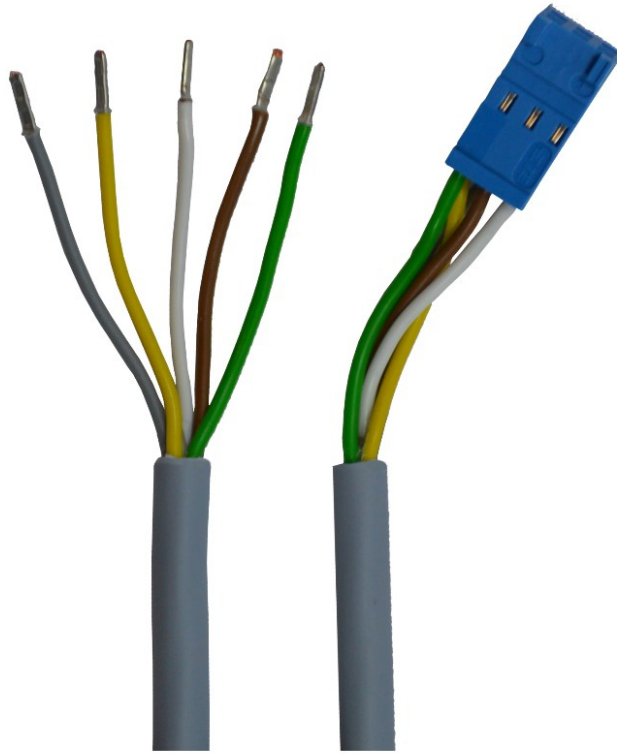

## Description

---

### BlueMatic Motor Unit

- Easy to install
- Retro fits to auto locking multipoint Lock
- Can be linked to an intercom system, remote control, etc
- Can be used on UPVC, wooden, aluminium or composite doors
- The lock is designed to accept a "screw on" 12v electronic motor which can then be controlled by means of industry standard access control systems.
- When activated the two solid high tensile steel hooks and central latch are withdrawn thus forming the blueMatic AV2-E. The extreme versatility of the blueMatic Electronic Locking system is achieved through its easy integration with all access control systems which subsequently leads to its suitability for many different applications.

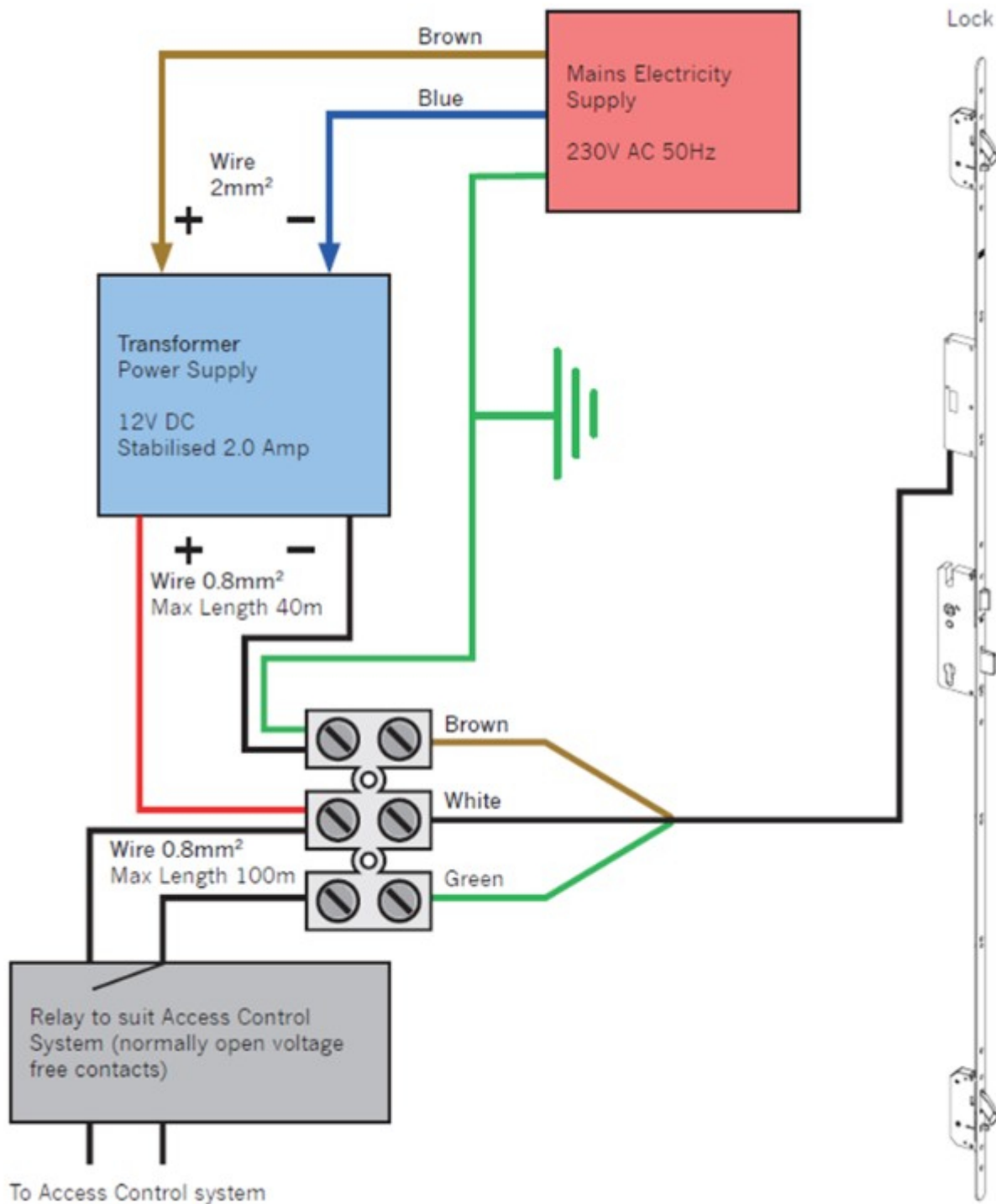

### BlueMatic Motor Unit Cables

- Factory fitted plug-in adapter
- 5 Core Wire
- 6 metre cable
- Colour coded for easy of installation
- This colour coded 5 core wire has a factory fitted adaptor and is specifically for use with the auto locking multipoint lock when fitting it with a motor for electronic operation.

### BlueMatic Motor Unit Armoured Door Loop

- Protects cable from door to the frame
- 2 metre cable
- This transition Cable is an armoured door loop which allows the wire to move from the door to the frame in an aesthetically pleasing and secure manner.

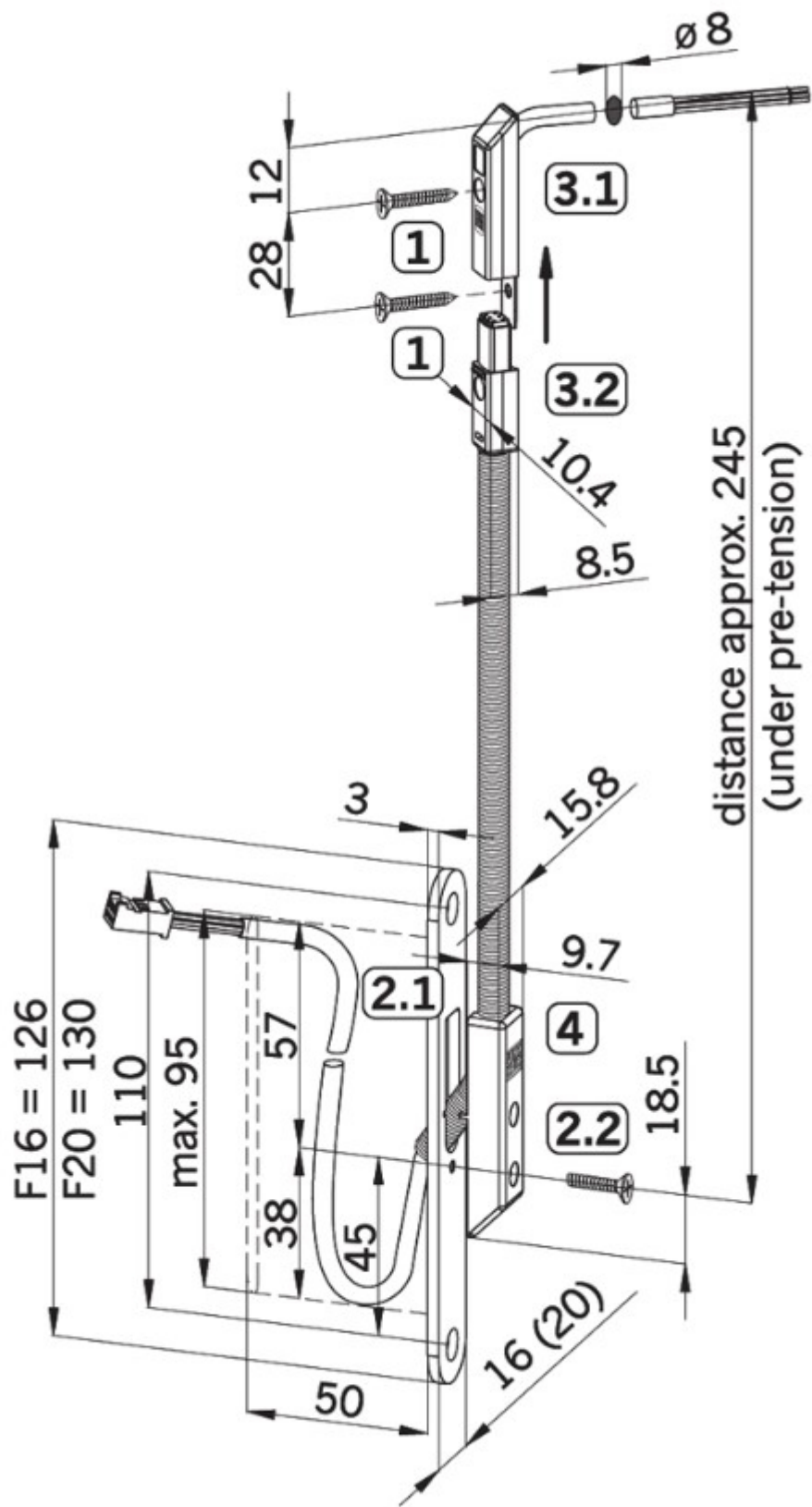

## Products in this set

---



44281.1 - Auto Locking Multipoint BlueMatic Motor Unit



44281.2 - Auto Locking Multipoint BlueMatic Motor Unit Colour Coded 5 Core Wire Cables - 6 Metres



44281.3 - Auto Locking Multipoint BlueMatic Motor Unit Armoured Door Loop - 2 Metres