

Sleeved Letter Plate Set - Draught Proof With Internal Brush - 310mm x 76mm - Black

Product Images

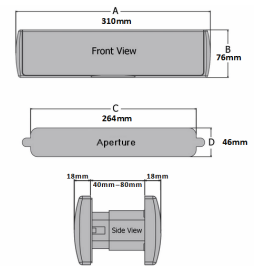

Description

- Draught proof sleeved letter plate set.
- Black finish.
- 310mm x 76mm high letterbox with "lift up" spring loaded flaps and internal weather sealing.
- A combination of external foam seals and internal nylon brushes maximises weather sealing and draught proofing.
- This letterbox has been designed in house by a specialist product development team and combines smart design features, reliable operation with a hard wearing contemporary finish.
- Design registered, with patent pending, the sleek frame and flap design incorporate a concealed flap operating mechanism to maintain subtle exterior sightliness.

- This letterbox features internal and external thumb access for ease of use. When fully open the internal and external flap opens to 180° without over stressing and smart frame design prevents abrasive action against the flap during operation.
- This letterbox is a telescopic sleeve set to suit door thickness between 40mm - 80mm.

Operation

- Lift up flap.
- Built in foam seal and internal brush.

Finish

- Black

Dimensions

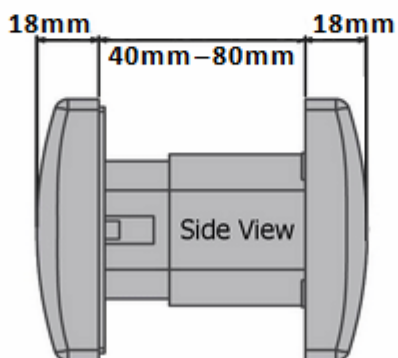
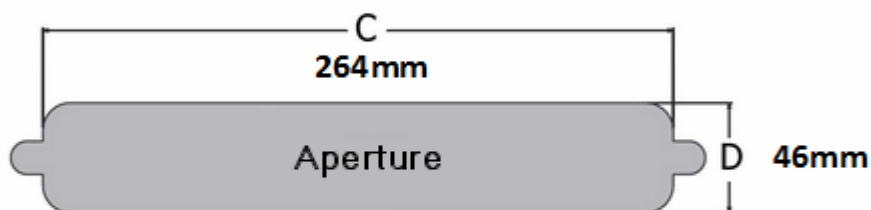
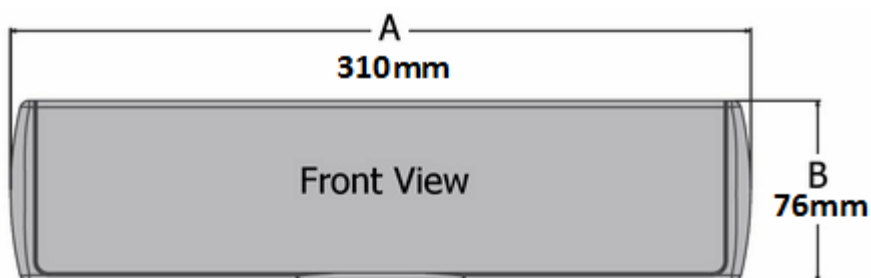

Item Code Overall Width - (A) Overall Height - (B) Aperture Width - (C) Aperture Height - (D) To Suit Door Thickness

44479.1 310mm 76mm 264mm 46mm 40mm - 80mm

Unit Of Sale

- Set - (includes both the external and internal plate).

Products in this set



44479.1 - Sleeved Style Draught Sealed Letter Plate Set - 310mm x 76mm - Black