FB2 London Fire Brigade Dead Lock - FD30 / FD60 Fire Rated - CE / UKCA Marked - Satin Stainless Steel

Product Images



Description

- FB2 London Fire Brigade mortice dead lock
- CE Marked / UKCA Marked, suitable for use on FD30 / FD60 fire doors.
- For use on internal doors, electrical cupboards and risers that need to be locked via an FB2 key.
- Comes supplied with a satin stainless steel (brushed finish) forend and frame mounted strike plate.
- **PLEASE NOTE THIS LOCK DOES NOT COME SUPPLIED WITH ANY KEYS.**

- Keys are sold separately - see product (**catalogue product number 40693**).

Operation

- Deadbolt is locked and un-locked via a key.

Features

- Solid stainless steel dead bolt.
- Works with a standard FB2 key.

Security Level

- Medium security architectural range.
- Suitable for use on internal and external doors in residential, commercial or public buildings.

Finish

- Satin stainless steel - (brushed finish).

Dimensions

- Available in one size only

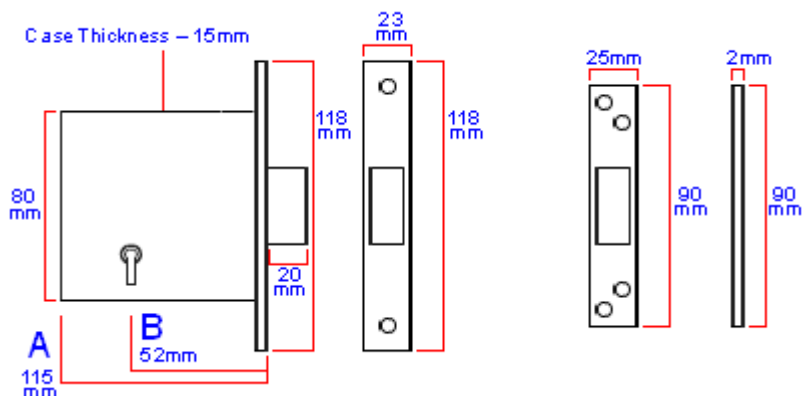

Item Code	Lock Case Depth (A)	Backset To Keyhole (B)
48211.1	115mm	52mm

Standards This Product Conforms To

- Tested and passed to BS EN 1634 the British / European standard for determining the fire resistance of door and shutter assemblies including hardware. Assessed for use on 30 minute and 1 hour timber fire doors FD30 / FD60- Intumescent lock case liners required (sold separately).
- CE Marked / UKCA Marked

Options Available To Order

- Intumescent sheets and lock case liners are available. Please see our intumescent fire rated products category for details.

Rebate Kit For Double Rebated Doors

- ARFB2SSS - 13mm satin stainless steel rebate kit for use with FB2 London Fire Brigade mortice dead lock.

Unit Of Sale

- Each - (1 x lock case supplied with forend and strike plate).
- KEYS SOLD SEPARATELY - (catalogue product number 40693).

Products in this set



48211.1 - FB2 London Fire Brigade Dead Lock - FD30 / FD60 Fire Rated - CE / UKCA Marked - 115mm Case Depth - (52mm Backset) - Satin Stainless Steel - Each