

Defender Friction Hinge - Top Hung - Stainless Steel - Six Sizes

Product Images

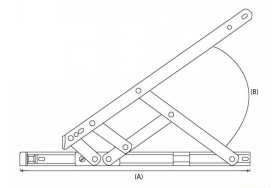

Description

- This Defender Friction Hinge has an accurate closure and a smooth operation
- Suitable for wood, UPVC and aluminium windows.
- Effective weather proofing and draft proofing with plastic ends.

Finish

- Stainless Steel

Dimensions

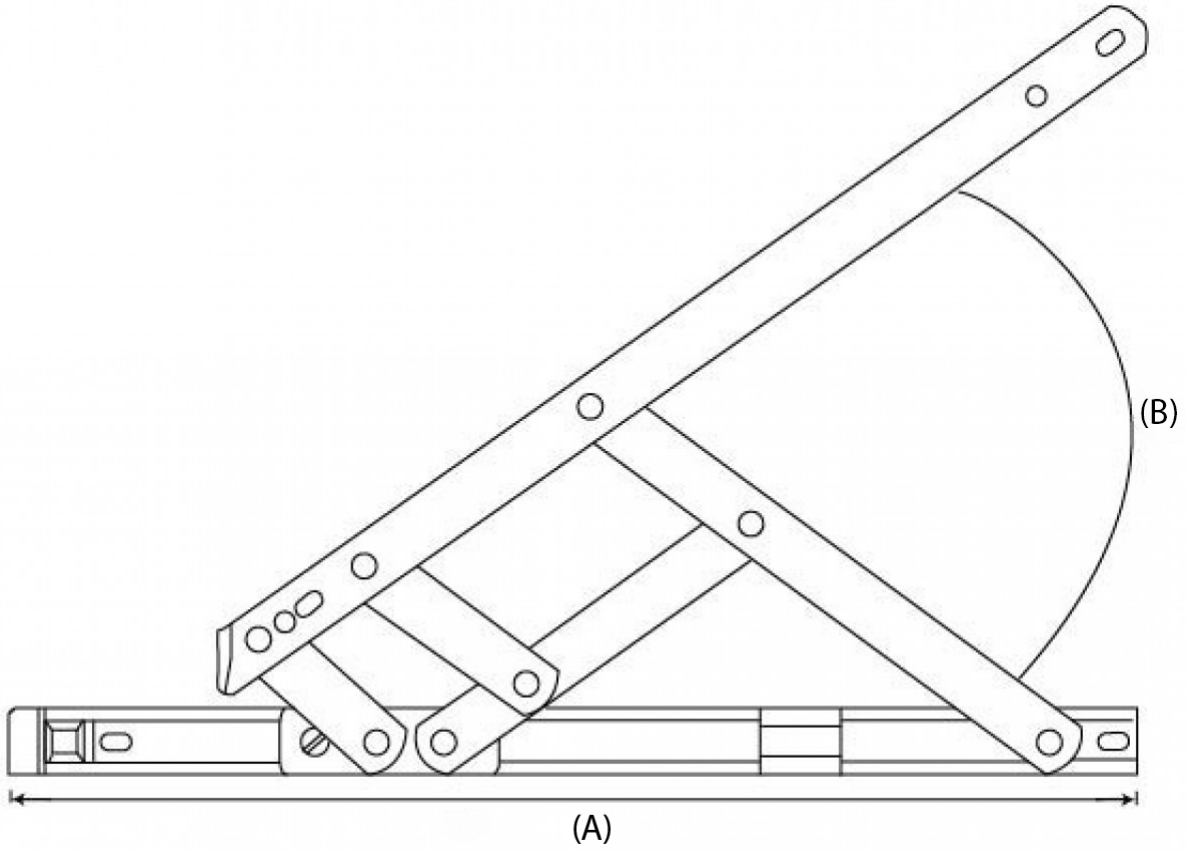

Item Code	Installed Length (A)	Opening degrees (B)	Stack Height	Max Weight
48222.1	203mm	50°	13mm	12kg
48222.2	254mm	80°	13mm	16kg
48222.3	304mm	80°	13mm	20kg
48222.4	406mm	80°	13mm	21kg
48222.5	508mm	50°	13mm	24kg
48222.6	609mm	37.5°	13mm	35kg

Important Info Before You Buy

- Sold in pairs without screws.

Products in this set



48222.1 - Defender Friction Hinge - Top Hung - 200mm x 13mm - Stainless Steel - Pair



48222.2 - Defender Friction Hinge - Top Hung - 254mm x 13mm - Stainless Steel - Pair



48222.3 - Defender Friction Hinge - Top Hung - 304mm x 13mm - Stainless Steel - Pair



48222.4 - Defender Friction Hinge - Top Hung - 406mm x 13mm - Stainless Steel - Pair



48222.5 - Defender Friction Hinge - Top Hung - 508mm x 13mm - Stainless Steel - Pair



48222.6 - Defender Friction Hinge - Top Hung - 609mm x 13mm - Stainless Steel - Pair