

Defender Friction Hinge - Side Hung - Stainless Steel - Two Sizes

Product Images

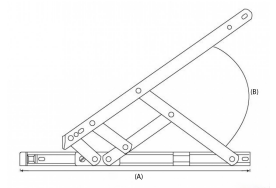

Description

- This Defender Friction Hinge has an accurate closure and a smooth operation
- Suitable for wood, UPVC and aluminium windows.
- Effective weather proofing and draft proofing with plastic ends.

Finish

- Stainless Steel

Dimensions

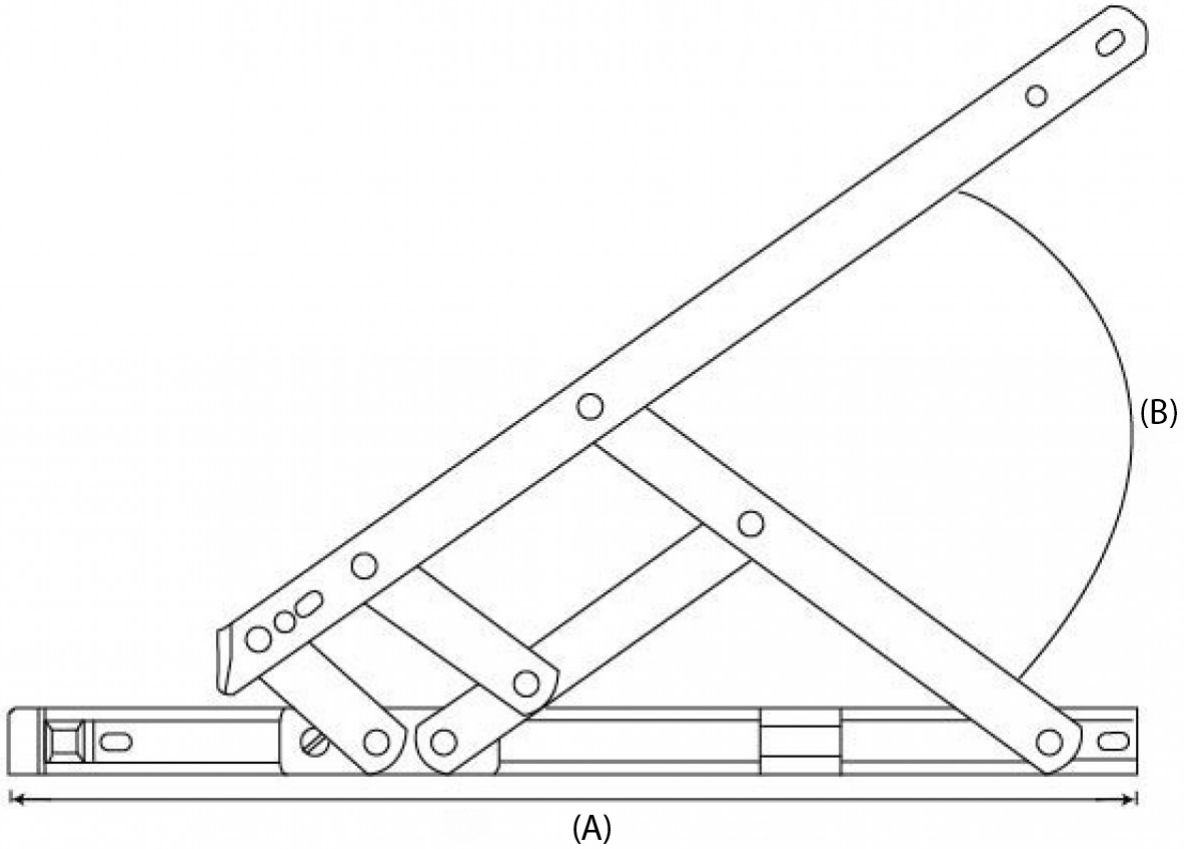

| Item Code | Installed Length (A) | Opening degrees (B) | Stack Height | Max Weight |
|-----------|----------------------|---------------------|--------------|------------|
| 48223.1 | 304mm | 60° | 13mm | 22kg |
| 48223.2 | 406mm | 60° | 13mm | 24kg |

Important Info Before You Buy

- Sold in pairs without screws.

Products in this set



48223.1 - Defender Friction Hinge - Side Hung - 304mm x 13mm - Stainless Steel - Pair



48223.2 - Defender Friction Hinge - Side Hung - 406mm x 13mm - Stainless Steel - Pair