

## Brompton Knurled Pattern Window Stay - Available In Three Sizes - Polished Chrome

### Product Images

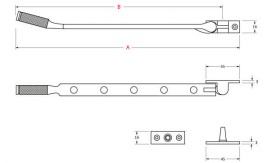

### Description

- The Brompton suite is a contemporary design, and features a textured knurled pattern
- The industrial styling of the diamond effect creates a modern range of products that can be used throughout your property
- Heavy weight pattern
- Knurled end design handle
- A casement stay is the handle or "arm" that fixes to the bottom of the window to help push the window open and pull the window closed
- The casement arm sits on pins this makes the window "stay" in position when in the open or closed position

### Finish

- Polished Chrome

### Dimensions

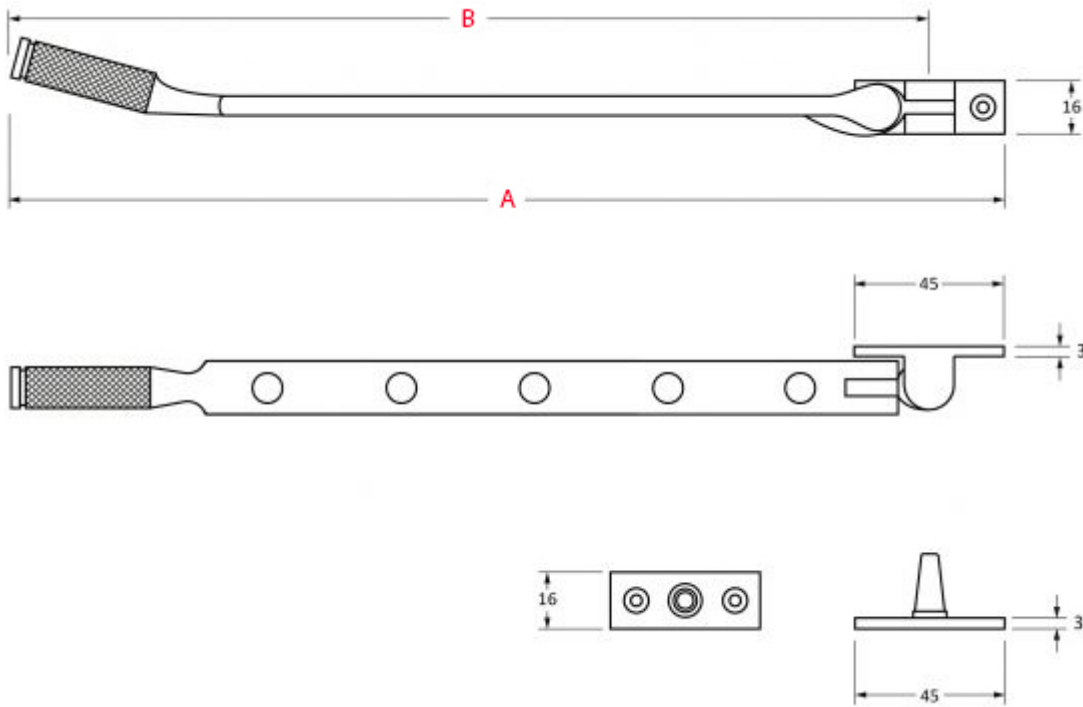

Available in three lengths

- Overall Size **A** On The Above Diagram

- 248mm Overall Length (8 Inches) - 49039.1
- 292mm Overall Length (10 Inches) - 49039.2
- 338mm Overall Length (12 Inches) - 49039.3

- Stay arm **B** On The Above Diagram

- 226mm - 49039.1
- 273mm - 49039.2
- 315mm - 49039.3

#### Important Info Before You Buy

- Suitable for use on wooden windows
- Suits standard outward opening casement windows
- Comes supplied with fixing screws and two standard pins
- Designed to match the Brompton window espags in the range

## Products in this set

---



**49039.1 - Brompton Knurled Pattern Window Stay - 248mm Overall Length (8 Inches) - Polished Chrome - Each**



**49039.2 - Brompton Knurled Pattern Window Stay - 292mm Overall Length (10 Inches) - Polished Chrome - Each**



**49039.3 - Brompton Knurled Pattern Window Stay - 338mm Overall Length (12 Inches) - Polished Chrome - Each**