

Octagonal Design Cupboard Door Knob - Two Sizes Available - Natural Smooth Cast Iron

Product Images

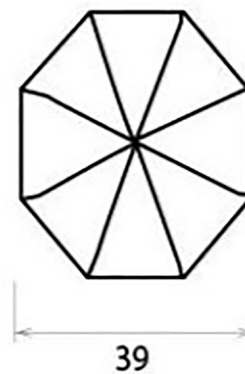
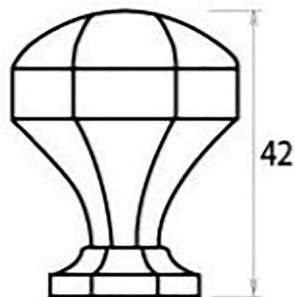

Description

- Octagonal Design cupboard door Knob
- The unique effect is achieved by individually hammering each product by hand
- Natural smooth products are made from a natural cast iron and finished with a clear matt lacquer
- High architectural quality range

Size Details

- Available in 2 sizes

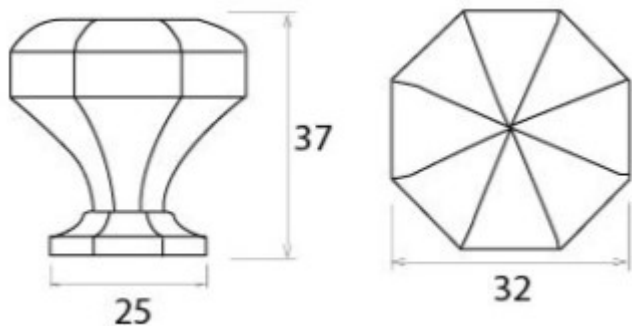

- Overall Size: 32mm Diameter
- Base Size: 25mm Diameter
- Projection: 37mm

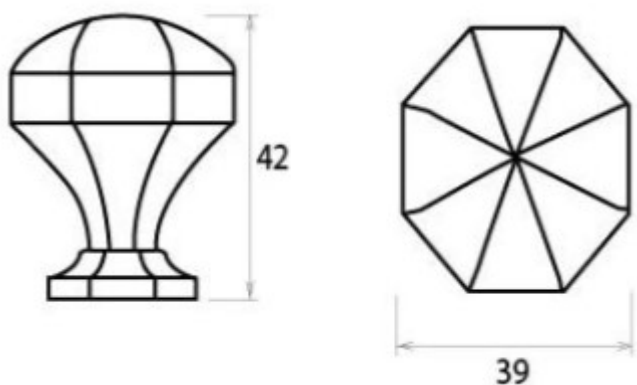

- Overall Size: 39mm Diameter
- Base Size: 25mm Diameter
- Projection: 42mm

Base Material

- Cast Iron

Finish Details

- Natural Smooth Cast Iron

Fixings

- This cupboard knob is fitted via a M4 bolt from the rear of the door / drawer - see below diagram

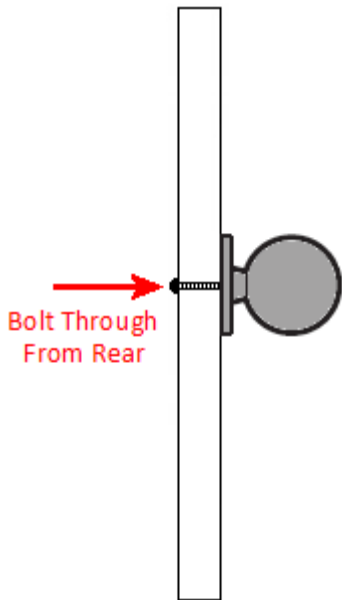

- Bolt through fixings provide a superior strong fixing allowing this knob to be fitted to tall or heavy doors
- Comes supplied with a 25mm long bolt - suitable for use on 18mm thick doors
- For doors thicker than 18mm, longer M4 fixing bolts are available to buy separately (See related products below)

Alternative Fixings

- For fixing two cupboard Knob back to back on either side of a door, a length of M4 stud is required to screw the two Knob together
- For face fixing a cupboard knob by screwing it directly into the front of a wooden door or drawer, a dual M4 / Wood screw is required

Usage

- Suitable for internal use
- For doors thicker than 18mm please purchase longer M4 fixing bolts (See related products below)

Unit Of Sale

- These cupboard Knob are sold individually - Each

Products in this set



49204.1 - Octagonal Design Cupboard Door Knob - 32mm Diameter - Natural Smooth Cast Iron - Each



49204.2 - Octagonal Design Cupboard Door Knob - 39mm Diameter - Natural Smooth Cast Iron - Each