

Modern Design Concealed Fixing Handrail Bracket - Matt Black

Product Images

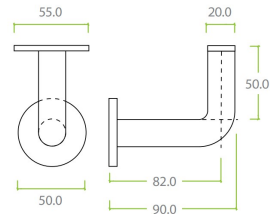

Description

- Modern style handrail bracket
- Threaded screw on rose
- Hidden concealed fixings - no screws seen once fitted
- Modern tubular design
- Meets the dimensional requirements of BS 8300 and approved Doc M (ADM)
- Fixings included
- Solid bar construction
- Suitable for flat based handrails

Finish

- Matt Black

Dimensions

- Projection - 90mm
- Rose (Backplate) Diameter - 50mm

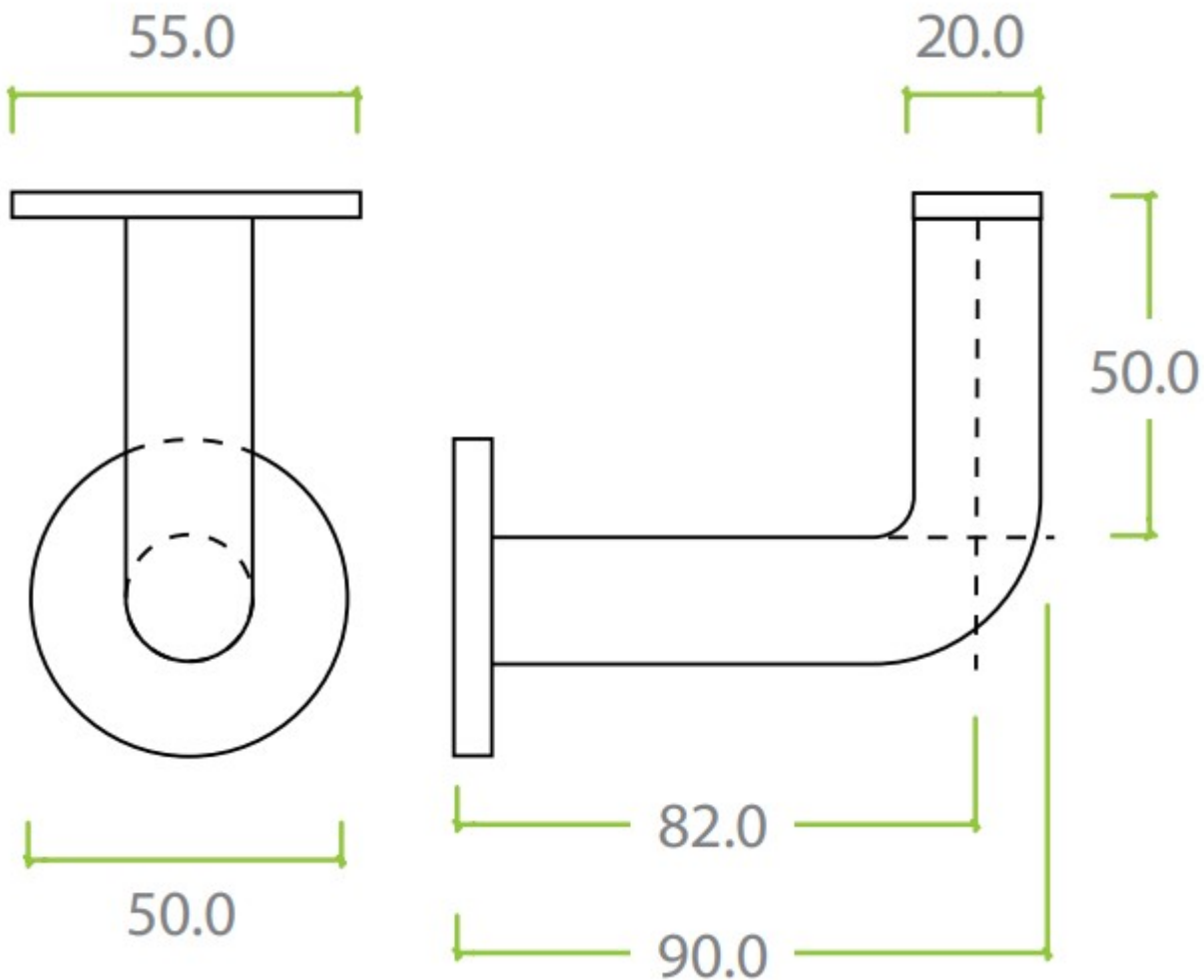

Unit Of Sale

- Sold individually - Each

Products in this set



49798.1 - Modern Design Concealed Fixing Handrail Bracket - 90mm Projection - Matt Black - Each