

---

## Architectural Quality Straight Arm Sash Window Fastener - Satin Chrome

### Product Images

---

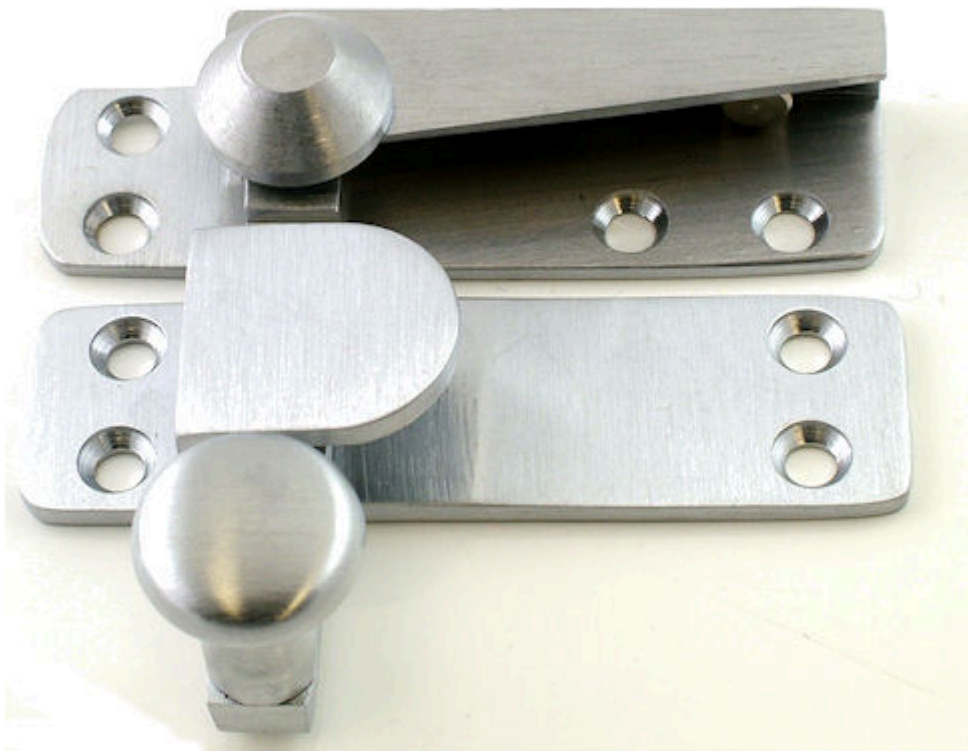

### Description

---

- Sliding sash window fastener
- Straight arm pattern
- High architectural quality
- When the fastener is in the closed position (when the arm is engaged in the receiver plate) the sliding sash window can not be opened

### Finish

- Satin chrome

## Dimensions

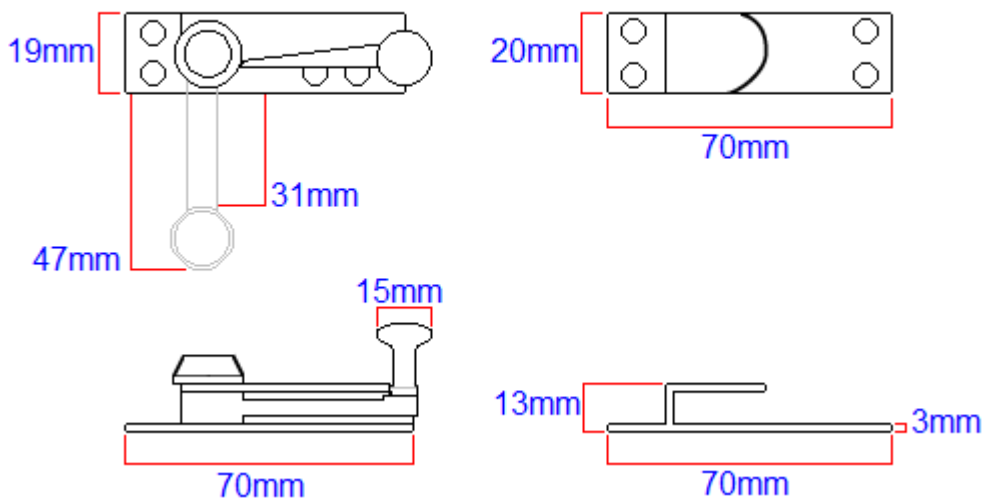

20969.1

Dimension On Diagram

**Back Plate Depth**

20mm

A

**Back Plate Length**

70mm

B

**Receiver Plate Depth**

20mm

C

**Receiver Plate Length**

70mm

D

### Important Info Before You Buy

- Suitable for wooden sliding sash windows
- This style of fastener is suitable for sash windows with flush fitting meeting rails (Where the two sashes meet in the middle they must be level or very close)
- For double glazed sliding sash windows with a narrow meeting rail a narrow pattern straight arm fastener is available
- Comes supplied with fixing screws
- Sold individually

### Products in this set



20969.1 - Architectural Quality Straight Arm Sash Window Fastener - Satin Chrome - Each