

---

## Architectural Quality - Fanlight Window Catch - Satin Chrome

### Product Images

---



### Description

---

- Spring loaded fan light window catch
- Architectural quality
- For use on bottom hung, inward opening fanlight windows
- Fitted with 29mm diameter ring pull for easy finger operation
- If the fan light window is fitted out of arms reach, for example in a high or awkward position a pole hook can be used to pull the ring to release

the catch

#### Finish

- Satin chrome

#### Dimensions

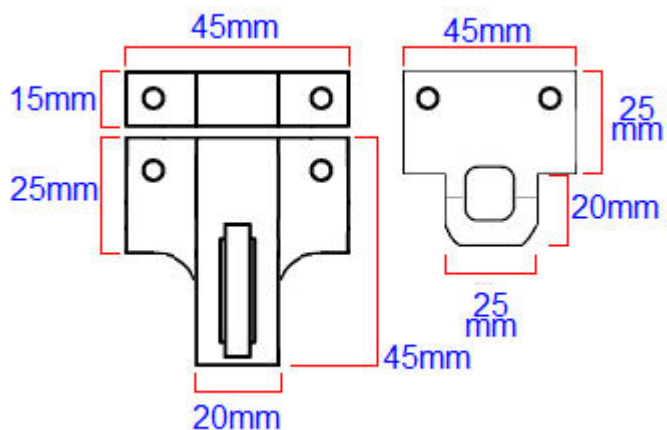

- Back Plate - 45mm (W) x 45mm (H)
- Staple Receiver Plate - 45mm (W) x 15mm (H)
- Flat Receiver Plate - 45mm (W) x 25mm (H)

#### Important Info Before You Buy

- Suitable for bottom hung inward opening wooden fan light windows
- Comes supplied with two options of receiver plates
  - Staple style receiver plate shown in above image (45mm x 15mm)
  - Flat plate style receiver plate shown in above image (45mm x 25mm)
- Sold individually

#### Products in this set



21764.1 - Architectural Quality - Fanlight Window Catch - Satin Chrome - Each