

## Gate or Railing Mounted Mailbox / Post Box - Black

### Product Images

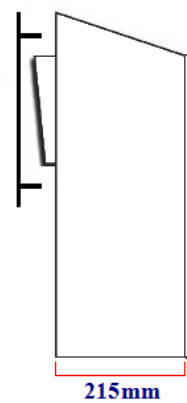
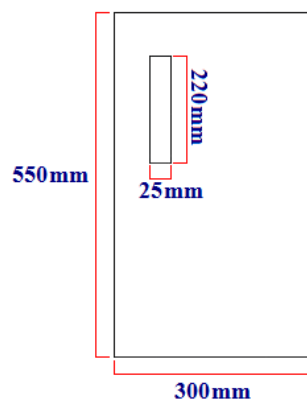

## Description

---

- Made of steel - Powder coated in a hammered black finish.
- To be mounted behind a fence or railing (fixings supplied).
- Lockable retrieval door.
- 2 keys supplied.
- Perspex nameplate.
- Fitted with Key lock
- External Dimensions 550mm x 300mm x 215mm (H x W x D).
- Vertical aperture 220 x 25mm.

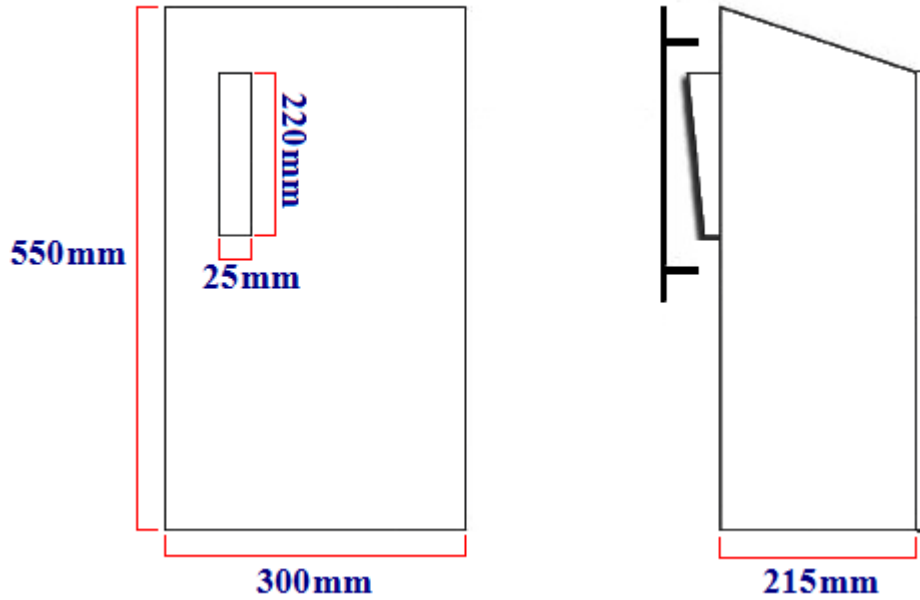

## Products in this set

---



40279.1 - Gate or Railing Mounted Mailbox / Post Box - Black