Modern Design Concealed Fixing Handrail Bracket - 90mm Projection - Polished Stainless Steel

Product Images



Description

- Stainless steel contemporary style handrail bracket.
- Threaded screw on rose.
- Hidden concealed fixings - no screws seen once fitted.
- Modern tubular design.
- Meets the dimensional requirements of BS 8300 and approved Doc M (ADM)

- Fixings included.
- Solid bar construction.
- Suitable for flat based handrails.

Finish

- Polished stainless steel - (shiny finish).

Alternative Finishes Available

- Satin stainless steel - (brushed finish).

Dimensions

- Projection - 90mm
- Rose (Backplate) Diameter - 50mm

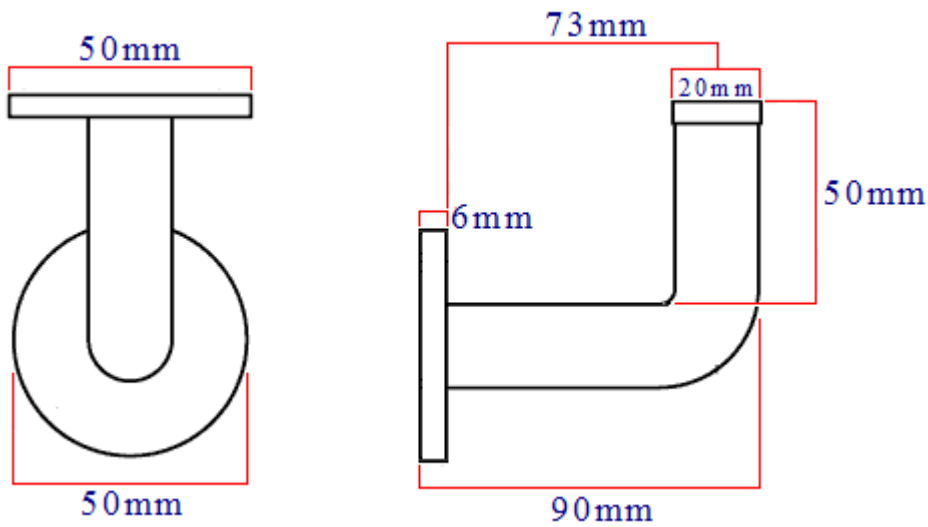

Products in this set



40707.1 - Modern Design Concealed Fixing Handrail Bracket - 90mm Projection - Polished Stainless Steel